

## Technical data

Bioclimatic UVC tunnel type 650

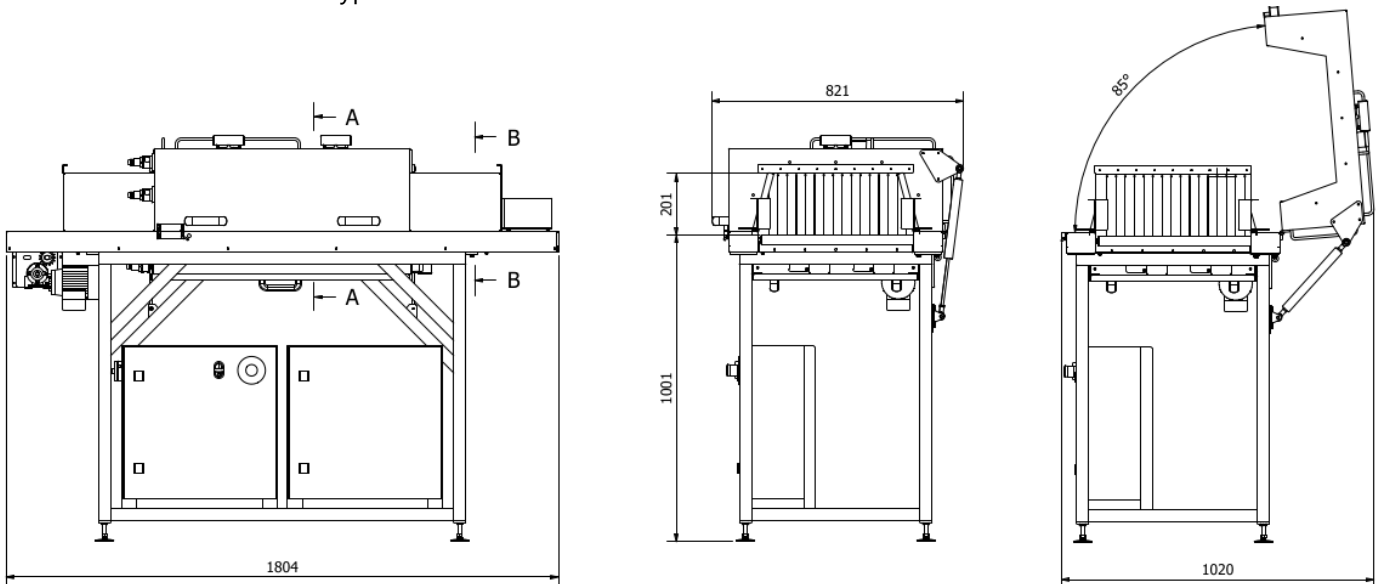

### Intended use and capacity

Suitable for product type:	packaged products
Length of product:	min. 200 mm
Diameter/height of product:	max. 180 mm
Controls:	Manual via buttons (start/stop)
Transport speed:	7 cm/s (4,2m/min)
Items/hr with product length 900mm:	approx. 240 pcs
Items/hr with product length 200mm:	approx. 800 pcs

### Mechanical

Dimensions:	1.800 x 820 x 1.330 mm (L x w x h)
Transport:	Stainless steel rollers
Tunnel entrance:	500 x 200 mm

### Materials

Machine en control cabinets:	Stainless steel 304
Reflectors:	PTFE
Safety curtains:	EPDM

### UVC

UVC dose delivered on product:	>40 mJ/cm <sup>2</sup> end of lamp lifetime
UVC lamps:	10 x 60 watt (Foodsafe sleeve optional)
Lamp lifetime:	12.000 hours

### Electrical

Voltage:	230V, 50hz
Consumed power:	650 Watts

*Complies with: European Machinery Directive (2006/42/EC), EMC directive 2014/30/EU, The low voltage directive (LVD) (2014/35/EU)*