

V500

VENTILATING AIR TREATMENT UNIT

A system without compromises

UVpro V500 ventilating air treatment units are ideal for subsequent installation and reliable treatment of any areas in industrial food production up to 450 m³/h. The two-stage ventilation system significantly increases the UVC dose to kill mold spores in a single run. Equipped with a corrosion-resistant reflector.

Two-stage ventilation system

Easy installation, also subsequently

For production, ripening, and storage rooms



SPECIFICATIONS

Type	UVpro V500
In conformity with requirements	EMC, CE, IP54
Material	stainless steel: WN 1.4301 and WN1.4305
Operating temperature [°C]	-10 to +40
Input power [W]	174
Current flow [mA]	790
Suitable UVpro lamp	UVpro KT40-4 (4x 41W)
Total UVC output [W _{253,7 nm}]	56
Air volume [m ³ /h]	250 / 450 (switchable)
Noise emission [dB]	34 / 41 (two-stage)
Mount	2 eyelets for chain attachment
Size (L x Ø) [mm]	1091 x 314
Weight [kg]	24.5
Lamp replacement interval [h]	12,000 (75% ^{+5%} output performance)
Life expectancy electronics	>10 years
Supply voltage [V _{AC}]	220-240 (50-60Hz)
Power cable length [m]	5 (length customisable)

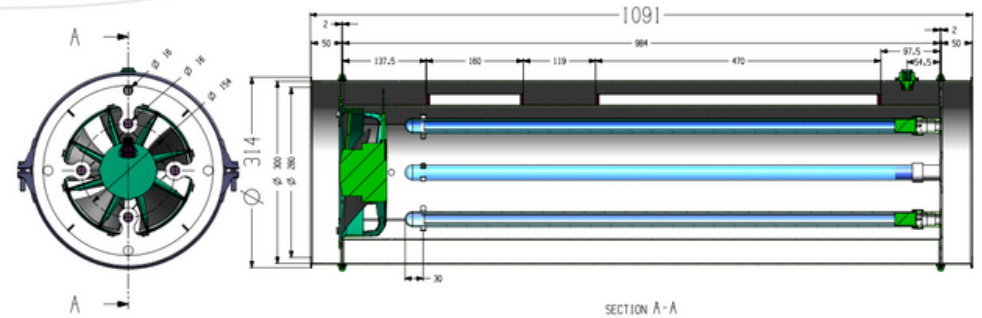

Application Optimised UV for



Food & Beverage
Industrial UV



Healthcare
Industrial UV



Pharmaceuticals
Industrial UV



Bioclimatic B.V.
The Netherlands

+31 252 626962
info@bioclimatic.nl
www.bioclimatic.nl